

Bendi
the original Bendi

Series 4 SPECIFICATION

BENDI B40 - 2,000 Kg

BATTERY ELECTRIC MULTI-PURPOSE ARTICULATED FORKLIFT TRUCK

The Bendi B40 is the origin of our range. Produced worldwide in quantities measured in thousands, the B40 is a machine with an enviable track record. As many companies around the world are discovering, the Bendi gives more than just its worth back - by eliminating double handling & saving space in the aisle.

FEATURES

- Electric
- 2 tonne capacity
- 9 metre lift
- 1.8 metre aisle
- Dual inside/outside capability

DRIVETRAIN

- Large 18", soft tyres.
- Twin 6 kW drive motors.
- Twin 10-tonne rated gearboxes.
- Twin 20:1 ratio disc brakes.

ELECTRICAL

- 48v high capacity 750 Ah battery, with fork pockets.
- Airblow & autofill cells an option.
- Reliable G.E. 'SEPEX' control.
- Full-featured battery & status display.
- Full wiring for road & spot lights.
- Provision for Radio Data Terminals.

ERGONOMICS/SAFETY

- Full hydraulic power steering.
- Cloth seat as standard.
- Arm-rest with all truck functions in one place.
- No 'deadman switch' needed as rotation happens in front of driver's cab.
- 4-post clearview adjustable overhead guard.
- Rearview mirror

ENGINEERING

- Full 3° back and forwards tilt.
- Triple mast specially designed for articulated forklifts as standard.
- Accepts any standard attachments.
- Rotation via 2x32-tonne taper bearings, with 3 year warranty on articulation.
- Robust cast chassis design.



SPECIFICATION

BENDI B40 - 2,000 Kg Series 4

BATTERY ELECTRIC MULTI-PURPOSE ARTICULATED FORKLIFT TRUCK

TECHNICAL &

Model			Bendi B40
Capacity		Kg	2,000
Load centre		mm	500
Power source			Traction battery
Unladen mass with battery			6,240
Travel speed	Laden/Unladen	kph	10.5/9.7
Lift speed	Laden/Unladen	m/s	3.0/3.5
Lower speed	Laden/Unladen	m/s	3.8/2.9
Tilt range	Fore/Rear	Deg.	<6m: 3/3, >6m 1/3
Overhead guard height	g	mm	2,210
Seat height	f	mm	1,220
Cab floor height	e	mm	720
Minimum ground clearance	d	mm	85
Lost load centre	a	mm	250
Overall length to face of forks	c	mm	2,570
Wheelbase	b	mm	1,540
Chassis width	h	mm	1,250
Maximum gradient		%	15
Lift motor rating		kW	9
Power steer motor rating		kW	1.5
Drive motor rating		kW	2x6
Wheel size	Front/Rear	mm	355 x 150/460 x 180
Battery type, standard			10 EPzB 750 - 750Ah
Min. battery weight		Kg	1,100 Kg
Control type			G.E. 'SEPEX'

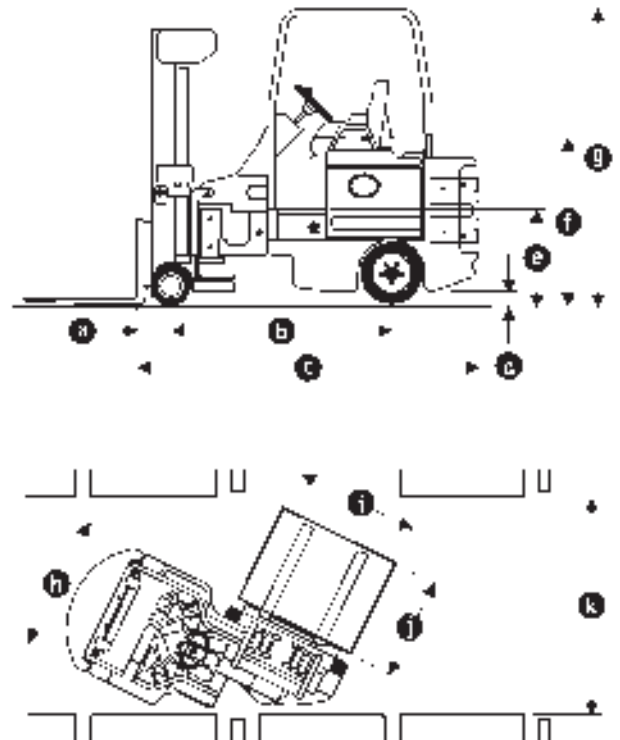

MAST DIMENSIONS

LIFT HEIGHT	FREE LIFT	CLOSED HEIGHT	EXTENDED HEIGHT	LIFT HEIGHT
4,775 mm	1,590 mm	2,260 mm	5,370 mm	4,775 mm
5,600 mm	1,866 mm	2,536 mm	6,198 mm	5,600 mm
6,050 mm	2,016 mm	2,786 mm	6,748 mm	6,050 mm
6,500 mm	2,166 mm	2,936 mm	7,198 mm	6,500 mm
7,200 mm	2,280 mm	3,400 mm	7,840 mm	7,200 mm
7,700 mm	2,450 mm	3,570 mm	8,350 mm	7,700 mm
8,200 mm	2,610 mm	3,730 mm	8,830 mm	8,200 mm
8,700 mm	2,780 mm	3,900 mm	9,340 mm	8,700 mm
9,000 mm	2,880 mm	4,000 mm	9,640 mm	9,000 mm

AISLE DIMENSIONS

LOAD DEPTH X WIDTH (j x i)	MINIMUM CLEAR AISLE (k)
1,000 x 1,200 mm	1,800 mm
1,200 x 1,000 mm	2,000 mm
1,200 x 800 mm	2,100 mm
MIN. CLEAR TRANSFER AISLE	2,500 mm

BATTERY INFORMATION

Ah CAPACITY*	V	CELL TYPE	QTY
750 Ah	48	10 EPzB 750	24
800 Ah	48	10 EPzBS 800	24

*CAPACITY QUOTED AT 5 HOUR RATE